

The Fiddle Mic: Miniature Condenser Microphone for Fiddle

DESCRIPTION

The Bartlett Fiddle Mic is a professional quality, miniature microphone that attaches to a fiddle or violin for recording or sound reinforcement. Specially voiced to sound best on a fiddle, the mic provides a warm, natural sound. It was designed with input from several prominent fiddle players. This microphone is recommended for soloists, duos, and acoustic groups without drums or electric instruments.

The Fiddle Mic was engineered based on extensive research into musical instruments and mic techniques. We measured, and listened to, the sound picked up in many locations on the body of several fiddles, and came up with useful recommendations for mic placement.

A fiddle tends to sound too bright or edgy when miked up close. The high-frequency response (treble) of the Fiddle Mic is rolled off to compensate, resulting in a smooth, warm sound.

The Fiddle Mic has a tiny mic housing with a rugged 10-foot cable attached to an XLR connector which houses the electronics. The microphone requires phantom power, available from most mixers.



FEATURES

- **Wide, smooth frequency response provides a natural sound -- much better than a pickup**
- **Tone quality is specially voiced for close-miking a fiddle**
- **Soft housing will not scratch your instrument**
- **Compared to a stand-mounted mic, the fiddle mic offers less clutter on stage, consistent volume and tone, and freedom of movement. No heavy mic stands to carry!**
- **High sensitivity and low-impedance balanced output provide a strong, hum-free signal**
- **Made in USA**

SPECIFICATIONS

Type: Miniature omnidirectional condenser microphone.

Transducer: Electret condenser.

Frequency response: 200 Hz to 20 kHz. See Figure 1.

Polar pattern: Omnidirectional. See Figure 2.

Impedance: 200 ohms. Recommended load impedance >1000 ohms.

Sensitivity: 26.6 mV/Pa (-32 dBV/Pa). 1 Pa = 94 dB SPL.

(Continued on other side)

Figure 1. Frequency Response

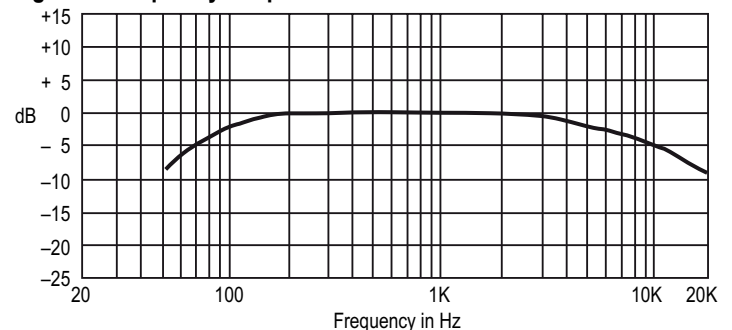
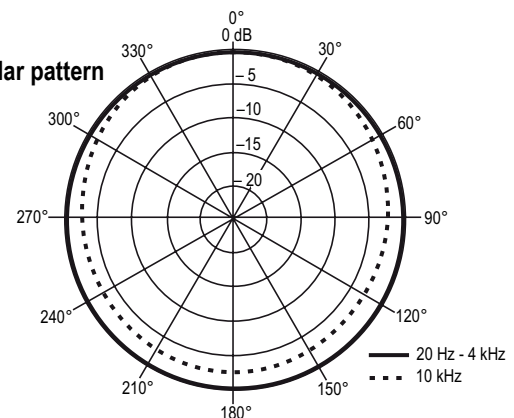

Figure 2. Polar pattern



Bartlett Microphones

Elkhart, IN USA

www.bartlettmics.com

email: bruce@bartlettmics.com

© 2011 Bartlett Microphones

Signal-to-noise ratio: >62 dB at 94 dB SPL. Noise is inaudible in normal use.

Maximum SPL: 130 dB SPL produces 3% THD. The mic will not audibly distort in normal use.

Cable: Permanently attached, 10-foot, black 2-conductor shielded cable with XLR-type 3-pin connector.

Operating voltage: 12–48V phantom power.

Current draw: 0.5 mA.

Materials: Rugged steel circuit housing.

Finish: Black.

Net weight: 2.8 oz (79 g).

Dimensions: XLR connector 2.460" long x 0.747" diameter, mic 0.540" long x 0.325" diameter.

Supplied Accessories: Two foam microphone mounts.

MOUNTING THE FIDDLE MIC ON YOUR INSTRUMENT

1. Supplied with the Fiddle Mic is a foam mount about 1 inch behind the mic. A spare foam mount is included.
2. Stuff the foam under the end of the tailpiece, with the mic cable closer to the tailpiece than to the fiddle body. The soft foam will not damp the fiddle's sound.

For a warm sound, angle the mic and foam toward the bass f-hole, and place the mic near the f-hole (see top photo at right).

For a bright sound, angle the mic and foam straight ahead so the mic is behind the bridge (see bottom photo at right).

3. Wrap the mic cable around the chin rest to prevent pulling the mic off.

OPERATION

1. Option 1: Plug the mic connector into a mic cable that is connected to a mixer mic input. That input should supply phantom power.
2. Option 2: Plug the mic connector into a mic cable that is connected to a phantom power supply. Then connect the phantom supply output to a mixer mic input.
3. Turn on phantom power before use.
4. The microphone is very sensitive or "hot". Be sure to turn down the input gain trim on your mixer as needed to prevent mixer distortion and feedback.
5. If you also use a pickup, send the pickup's signal only to the monitors, and send the mic signal only to the house speakers. That will reduce feedback.

WARRANTY

The Bartlett Fiddle Microphone is guaranteed not to malfunction (except in cases of abuse) for a period of two years from the date of first purchase. Mic cables and paint finish are excluded from this warranty.

Miking over or near the f-hole gives a warmer sound. Caution: mic placement on the fiddle surface, over the f-hole, may result in feedback.



Miking behind the bridge gives a brighter sound:



SERVICE

For tech support email bruce@bartlettmics.com.

If the microphone does not operate correctly, first check its cable and other connected cables. Repair or replace them if necessary. Make sure that phantom power is turned on and that the microphone's fader is up in the mixer.

If the microphone still fails to operate, obtain a return authorization number from us by emailing bruce@bartlettmics.com. Then return the mic and its cable in its original packaging to Bartlett Microphones. Please include proof of purchase and a note about the problem.

If the microphone's specifications change, any changes will appear in the latest data sheet available online at www.bartlettmics.com.