

## TEN TIPS TO REDUCE FEEDBACK

by Bruce Bartlett, Bartlett Microphones  
Copyright 2009

SQUEAL! It's our old friend, feedback. Feedback in a sound system is that annoying howling or squealing tone you hear when the microphones pick up amplified sound from the loudspeakers. Sound from the speakers enters the mics, is re-amplified, and goes around in a feedback loop (Fig. 1). Almost instantly, the sound builds up until a loud tone occurs -- usually at a single frequency.

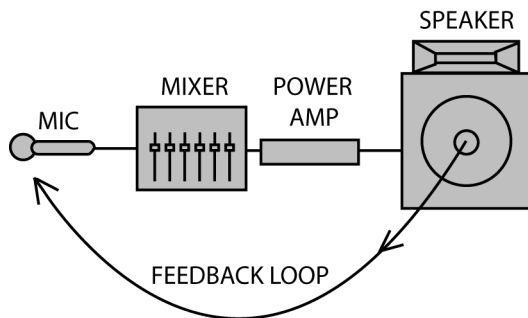

Fig. 1. The components in a feedback loop.

Feedback can be a major problem in theater sound. Often the actors don't project their voices (especially in school productions), so the mic gains must be turned up high in order to hear them - - causing feedback. In budget productions that use only floor microphones, those mics are far from the performers, so they require lots of gain. Even in high-end productions with several wireless mics in use, feedback can happen when several microphones are on at the same time.

Fortunately, there are many ways to kill feedback or prevent it in the first place.

**1. QUICK FIXES:** At a rehearsal, turn up each mixer mic fader to the point where feedback just begins to start (where you hear a slight ringing tone). Mark that point next to each fader. Don't exceed those marks during the performance.

If you still hear feedback during the show, turn down the mixer master faders a little until feedback stops. If you know which mic is causing the feedback, turn down its fader. Better yet, cut EQ at the frequency which is feeding back.

**2. USE AS FEW MICS AS POSSIBLE.** The more microphones you have in use, the higher is the chance of feedback. So turn down unused mics. This increases clarity as well as reducing the potential for feedback.

At this point we need to define "gain before feedback." It is the amount of amplification a sound system can achieve just before it starts to feed back. A sound system with high gain-before-feedback can amplify a mic's signal quite a bit before feedback starts, resulting in loud amplified speech. Systems with low gain-before-feedback sound quiet because the faders can't be pushed up very far without feedback occurring.

The gain-before-feedback decreases 3 dB each time the number of open mics doubles. Two mics have 3 dB less gain-before-feedback than one mic; four mics have 3 dB less gain than two mics, and so on.

To reduce the number of open mics, turn off (mute) any mics not in use at the moment. You might prefer to turn them down about 12 dB, rather than off, so you don't miss cues.

Let's give an example. Suppose you are using three stage-floor mics placed left, center and right. An actor walks in from the left and talks while moving to the right. So you'd turn up the left mic first, then crossfade to the center mic, then crossfade to the right mic.

Or suppose there are groups of actors near the left and right sides of the stage, but none in the middle. Turn down the center mic during that part of the play.

**Try the A-B loudspeaker scheme:** Assign each mic to a separate output bus, with each bus feeding its own power-amp channel and loudspeaker. That way, you create 2 to 4 independent PA systems, each with one mic and one speaker. That practice minimizes the number of open mics per PA system, which reduces feedback. Mount the speakers close together so that the reproduced actor's voice does not shift when the actor walks from left to right. This system also reduces phase interference (comb filtering) when two or more mics are on at the same time. With this arrangement, you might not need to turn mics up and down to follow the actors.

**3. PLACE SPEAKERS AND MICS FAR APART.** This weakens the sound traveling from speaker to mic, so it diminishes the feedback loop. Try to mount the house speakers far from the mics. Also, use large speakers with horn-loaded tweeters, or line arrays, that focus the sound on the audience.

**4. USE UNIDIRECTIONAL FLOOR MICS.** A mic with a unidirectional polar pattern picks up sound mainly in one direction -- in front of the mic. It rejects sound sources to the sides and rear of the mic, such as the pit orchestra and the PA speakers. In general, a unidirectional mic provides more gain-before-feedback than an omnidirectional mic. Two types of uni patterns in floor mics are half-cardioid and half-supercardioid. To reduce feedback, use a half-supercardioid floor mic (like a Bartlett Microphones TM-125) instead of a half-omni (hemispherical) floor mic.

The microphone data sheet specifies the type of polar pattern that a mic has.

Some sound engineers have had success with shotgun mics on floor stands at the footlights. The longer a shotgun mic is, the better it works at low frequencies. Note that shotguns have a very tight pickup pattern, so it's easy for actors to get off-mic unless you use several mics and ride gain on them.

**5. PLACE SPEAKERS BEHIND MICS.** Unidirectional mics reject sound arriving from behind the mics. We want the mics to reject the speakers. So try to place the house loudspeakers toward the audience, and away from the stage.

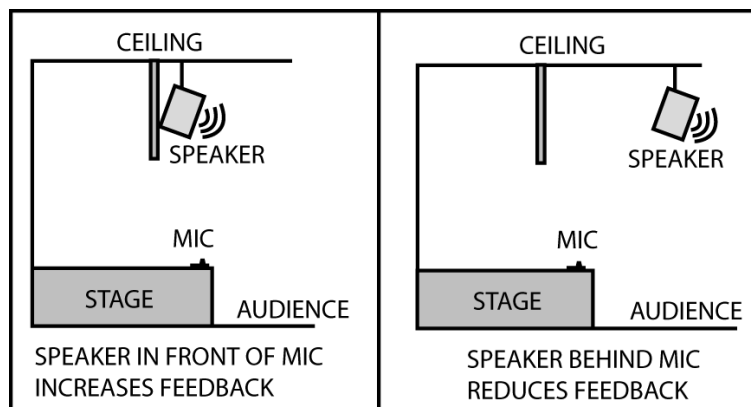

*Fig. 2. Speaker placement affects the likelihood of feedback.*

**6. MIKE CLOSE.** This is the most effective method to reduce feedback. Close miking increases the sound level at the microphone and makes the sound system louder. Place each wireless mic as close as you can to the mouth. To do that, use a headworn mic with the mic capsule just off

the side of the mouth. Or tape a lavalier mic's cable to the actor's cheek using Hy-tape, 3M Nexcare waterproof bandages, or Band-aid Water-Block Plus bandages. They are available online or in the first-aid section of pharmacies.

An alternative is to run the mic cable through the hair, with the mic hanging just below the hairline on the forehead. Be sure to use a water-resistant mic to prevent sweat damage.

Omnidirectional mics are usually the best choice for headworn or lavalier use. Omni's generally have a wider, smoother response than uni's and pick up less handling noise and clothing noise. If a mic is very close to the mouth, it picks up a high sound level -- so you can use an omni mic in that application.

If an actor is not loud enough through the PA without feedback, move the mic closer to the mouth, or ask them to talk more loudly. The director should mention to them that they can't be heard if they don't project.

If you have poor gain-before-feedback while picking up a group of singers with a floor mic, you might give each singer a handheld wireless mic (if it suits the production). Otherwise try hanging a small cardioid mic over and in front of the group, aiming at them.

Sometimes the actors might be upstage, far from the floor mics, where they can't be heard well. It can help to mount a boundary mic on the set near the action, or hang a miniature mic there. That way a mic will be near the actors, providing a louder pickup.

Also, place floor mics as close to the actors as possible without getting in their way. This has three benefits:

1. The mics receive a higher SPL, which increases gain before feedback.
2. The mics are farther behind the house speakers, which increases gain before feedback.
3. The mics are farther from the pit orchestra, so they pick up less orchestra.

**7. REDUCE COMPETING SOUND.** This tip doesn't reduce feedback, but it may let you not turn up the mics so much. Sometimes you can't hear singers because the pit orchestra is playing too loudly. You might tactfully explain the situation to the musical director. Some theaters place the pit band in a separate room and mic them. Also, consider reducing the noise of the air-handling system.

**8. EQUALIZE THE PA SPEAKERS.** A handy tool for removing frequencies that feed back is a graphic equalizer. The equalizer has a row of controls that affect the level or loudness of various frequency bands from low to high (Fig. 3). You connect this device between the mixer output and the power-amp input. Basically, you find the frequencies that are feeding back, and turn them down on the equalizer.

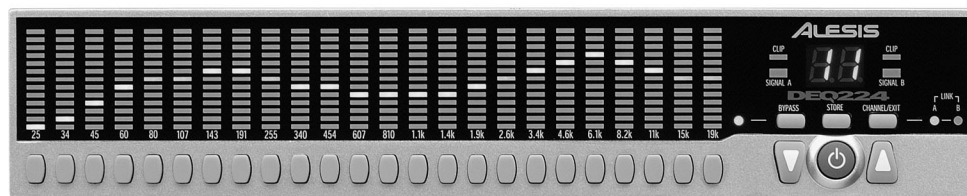

Fig. 3. An example of a graphic equalizer: the Alesis DEQ224.

Automatic feedback suppressors, such as made by Sabine and Shure, will do this for you. They quickly sense feedback and determine its frequency. Then they assign a narrow notch filter at the same frequency, which eliminates the feedback. Several filters are assigned for different feedback frequencies. Caution: some budget feedback suppressors use wideband notch filters which affect the tone quality. Also, since they cut out a wide band of frequencies, they can actually reduce the gain-before-feedback.

If you want to use a graphic equalizer, follow these steps:

Set all the graphic-equalizer controls to their center position ("flat"). The rows of volume controls toward the left of the equalizer affect low frequencies; those on the right affect high frequencies. If you push a control up (apply boost), the level or volume increases at a particular frequency. If you push a control down (apply cut), the volume decreases at that frequency.

It's likely that only the floor mics or hanging mics will need graphic EQ. Set up a normal production mix of the floor mics. Now slowly turn up the mixer's master faders to bring up the volume in the PA speakers. The system will start to feed back, sounding like a musical note or tone. Try to find this note on the equalizer by cutting (pushing down) each control in turn. The control knob that stops the feedback is the correct one. Lower this control just to the point where the feedback stops. Then turn up the mixer's master faders until the system feeds back again (usually at a different frequency). Lower the control for that frequency until feedback stops.

Repeat this procedure several times, turning up the overall volume as feedback is suppressed, so that three-to-five frequency ranges are cut. You should be able to play the house speakers louder without feedback than you did before equalization.

**9. PLACE SPEAKERS CLOSER TO THE AUDIENCE.** Close speakers sound louder than distant speakers, so this increases gain-before-feedback. Thanks to the inverse-square-law, the SPL of the direct sound increases 6 dB each time the distance to the speaker is halved. A typical close loudspeaker placement might be about 10 feet above the third row of seats (Figure 4). If your theater uses distant speakers, you might remove them and hang them closer to the audience. Be sure to rig the speakers very securely with safety codes in mind.

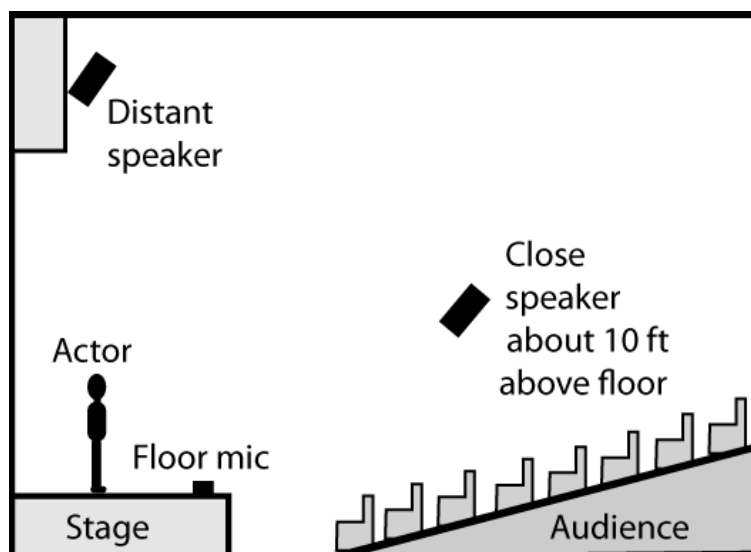

SIDE VIEW OF THEATRE

Figure 4. Distant versus close speaker placements.

Another advantage: With close-up speakers, the audience hears a lot of clear direct sound, straight from the speakers. With distant speakers, the audience hears a lot of muddy-sounding room reflections. Close speakers sound more intelligible than distant speakers.

Still another advantage: Placing the loudspeakers near the audience puts them on the "dead" backside of the cardioid stage mics, which allows more gain.

If you use closer speakers, make sure to use enough of them so that the audience is covered uniformly with sound. Also make sure that the dispersion angle of each speaker is wide enough (usually 90 to 120 degrees) to cover the audience uniformly.

Delay the signal going to the close-up speakers so that the sound is localized at the stage. Here's how: Listen to the sound system from far back in the audience area. Starting with minimal delay, gradually increase the delay until the sound appears to come from the actor on stage instead of from the nearest speaker. You're using the precedence effect (Haas effect). A delay of 20 msec might be a starting point.

**10. USE A LINE ARRAY OR COLUMN SPEAKER OVERHEAD.** It projects much less sound onto the stage than a conventional speaker.

Good luck in your quest to tame feedback!

###